



Gooseneck Service body

Catalog

2024

1



The Martin EcoMax Gooseneck service body is designed for continuous hard work and comes with standard features that exceed expectations. What separates this body from the competition is the structure, it has extruded 3/16 grooved floor with crossmembers every 8" and the boxes are made from 1/8 aluminum sheeting welded together and sealed with truck body caulk. The doors are bolted together so there are no weld marks on the outside, they come with compression latches and automotive bulb seals, producing the most watertight compartments available. The whale tail door latches are rivet-less for added protection. All compartments incorporate nitrogen gas springs.

With a universal mounting kit and plug-and-play wiring, this is an all-aluminum service body that installs easily and works hard everywhere.

standard features

- Headboard with stop-turn lights (all lights are LED)
- 3 sealed compartments per side
- Front tall compartments have 2 adjustable shelves with dividers.
- Heavy slam latch tailgate with stainless steel lock rods
- Diamond plate step bumper with LED lights
- 6061 Extruded grooved floor planks
- Gooseneck access lid
- 4 recessed D-rings in the floor
- Martin's universal mounting for bed delete trucks or 4" long rail with poly for cab & chassis trucks.
- 3-year warranty on materials and workmanship, 1 year on components such as latches and lights

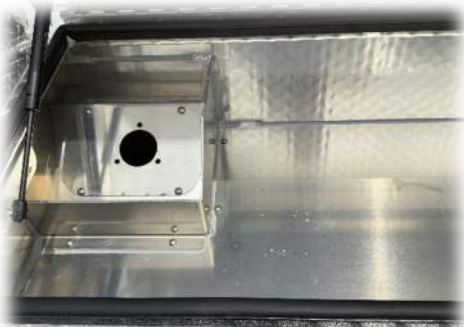

Fuel fill port in driver side top loading box



Gooseneck access lid



front box



Bed sizes and dimensions

Part #	Cab to Axle	Weight	A	B	C	D	E	F	G	H	I	J
GNSB-AL-84x80	36"		80	84	15	23	42	65	15.5	34x10	16x11	11.5x53.5
GNSB-AL-84x84	40" and 42"		84	84	16	22	46	68	15.5	34x11	16x10	11.5x56.5
GNSB-AL-84x100	56"		100	84	31	23	46	69	15.5	34x26	16x11	11.5x57.5
GNSB-AL-84x110	60"		110	84	35	29	46	75	15.5	34x30	16x17	11.5x63.5
GNSB-AL-98x100	56"	855 LB	100	98	31	23	46	69	22.5	34x26	16x11	18.5x57.5
GNSB-AL-98x110	60"	950 LB	110	98	35	29	46	75	22.5	34x30	16x17	18.5x63.5
GNSB-AL-98x134	84"	1250 LB	134	98	59	29	46	75	22.5	34x30	16x17	18.5x63.5

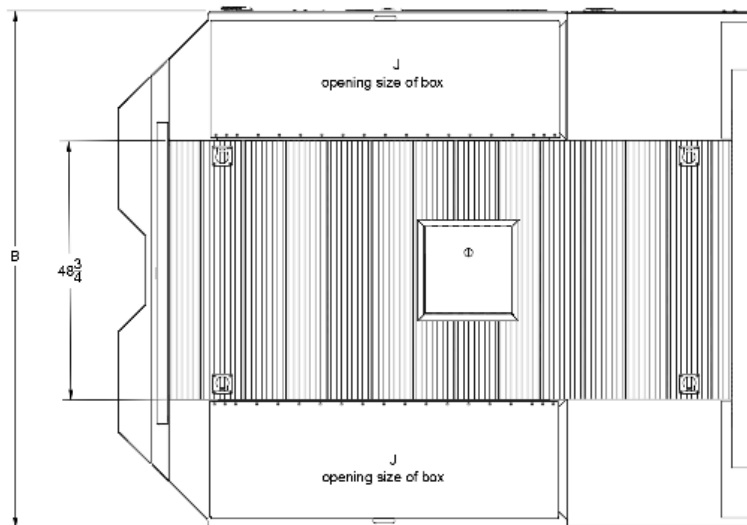
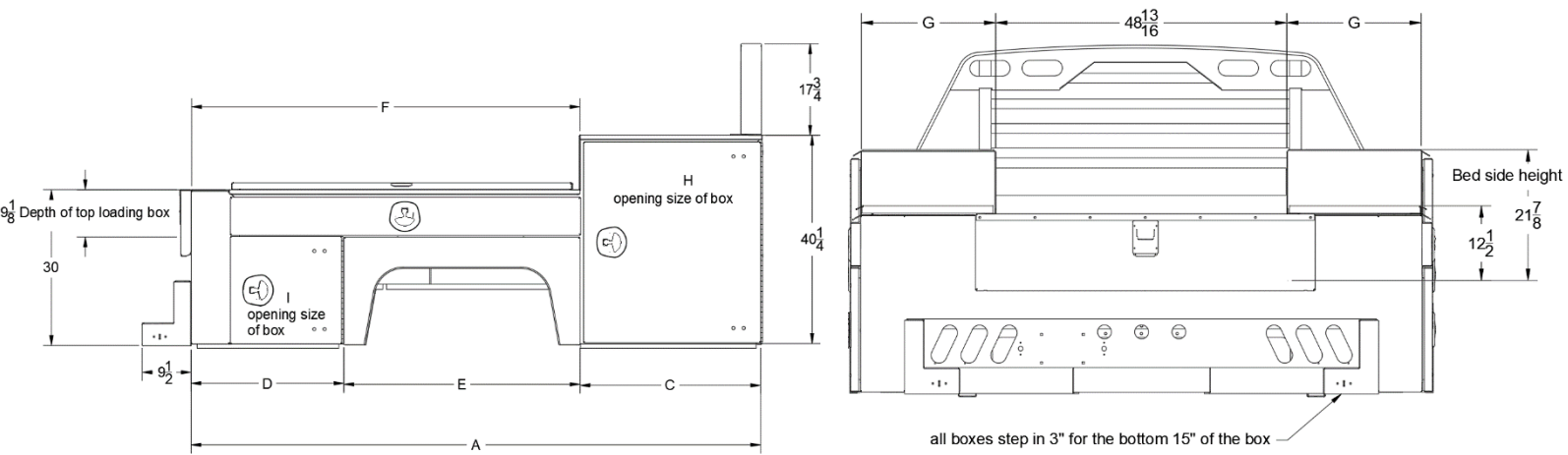



Paint Options



SBO-210



SBO-255 & SBO-256



SBO-113 & SBO-255



SBO-211

Part #	Description
SBO-200	Accent paint on Service Body doors and tailgate only 8 & 9 ft bodies
SBO-210	Accent paint on Service Body doors and tailgate only 11 ft bodies
SBO-215	Paint upgrade on red, pearl paints, or special metallics
SBO-211	Paint on back of body
SBO-212	Paint on front of body
SBO-113	Paint on complete body
SBO-255	Spray-on Scorpion bed liner bed floor and sides*PA builds*
SBO-256	Spray-on Line-X bed liner bed floor and sides *MO builds*
SBO-216	Accent powder coat, 8-9ft bodies *PA builds only, black, or white *



Lighting Upgrades



SBO-316

SBO-317

SBO-315



SBO-300 & SBO-301



SBO-09-5

SBO-09-1

Part #	Description
SBO-300	(6) LED Compartment strip lighting on door switches
SBO-301	(8) LED Compartment strip lighting on door switches
SBO-315	M5 Marker light upgrade package
SBO-316	(2) Work lights in headboard (prewired)
SBO-317	(2) Work lights in rear panel of body (prewired)
FBO-09-5	15" Strobe bar on headboard
FBO-09-5-1	Bracket only for 15" Strobe bar on headboard
FBO-09-1	Flush mount strobe package, 2 on rear, 2 on the headboard
FBO-06	Clear lens light upgrades



SBO-06

GNSB Compartment Upgrades

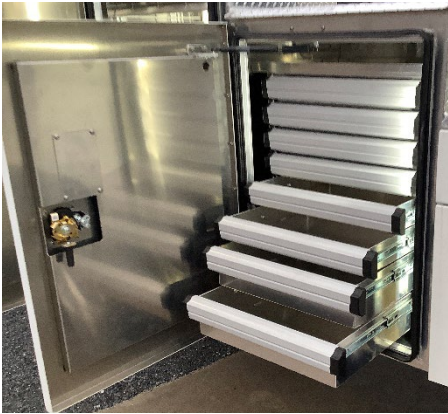

Standard drawer set.



Short bed drawer set.



Service body shelves with dividers.

Part #	Description
SBO-800	8-Drawer Toolset, 26" wide, (Fits 98x110 Body)
SBO-801	8-Drawer Toolset, 21" wide, (Fits 98x100 Body)
SBO-802	8-Drawer Toolset, 21" wide, (Fits 98x136 Body)
SBO-805	8-Drawer Toolset, 26" wide, (Fits 84x110 Body)
SBO-806	8-Drawer Toolset, 21" wide, (Fits 84x100 Body)
SBO-815	8-Drawer Toolset, 8" wide, (Fits 84x84 Body)

Part #	Body size	Shelf size	Part #	Body Size	Shelf size
SBP-S1214	84x80	12 ¼ x 14	SBP-S2821	98x100	28 ¼ x 21
SBP-S1211	84x84	12 ¼ x11	SBP-S2818	98x100	28 ¼ x 18
SBP-S1314	84x84	13 ¼ x14	SBP-S3221	98x110	32 ¼ x 21
SBP-S1311	84x84	13 ¼ x11	SBP-S3218	98x110	32 ¼ x 18
SBP-S2814	84x100	28 ¼ x 14	SBP-S2621	98x136	26 ¼ x 21
SBP-S2811	84x100	28 ¼ x 11	SBP-S2618	98x136	26 ¼ x 18



Part #	Description
SBO-810	Drawer set divider kit, spaced at 4"



Part #	Description
SBO-480	3000- Watt power inverter w/ Battery installed on a shelf

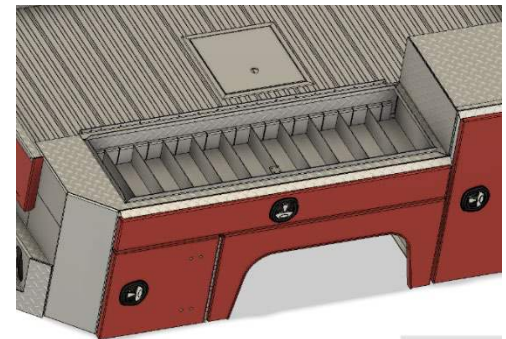

Part #	Description
SBO-327	GNSB top loader divider package



Description	
SBO-405	Transverse / crossover box Between front compartments



Description	
SBO-410	57" Tall front box



Description	
SBO-411	34" tall front box (for camper clearance)

Headboard Options



SBO-430 Standard headboard



SBO-430-BW Headboard for slider window and third brake light camera



SBO-430 Headboard for cab high boxes

Fuel Cell



SBO-770

SBO-765



SBO-755

Part #	Description
FT-45	45 Gallon Fuel Tank, 48"x20"x12"
FT-75	75 Gallon Fuel Tank, 48"x20"x20"
FT-115	115 Gallon Fuel Tank, 48"x20"x30"
SBO-775	Mounting Fuel tank in service body
SBO-755	15GPM Fill-Rite Aux Pump w/ Filter, Auto Nozzle (setup on top of the tank)
SBO-756	Upgrade to install Fuel pump in front compartment
SBO-770	Install "Reel craft" 25' Spring rewind Reel in Compartment

Additional Options



Part #	Description
SBO-501	Power locking door system, on key FOB



Part #	Description
SBO-???	Flip out step installed. In bumper or wheel well



Part #	Description
SBO-375	Vise mount welded on back of service body



Part #	Description
SBO-626	Rear removable ladder rack



Part #	Description
SBO-402	Underbody storage area between main sills of body 28" Wide x 4" High x 38" Long



Part #	Description
SBO-412	Smooth appearance package, (No Diamond plate on body)



Part #	Description
SBO-350	Dia. Chip guards on service body



Part #	Description
SBO-440	Round wheel well



Part #	Description
SBO-204-6	Body setup to reuse BLISS

Hitch Options

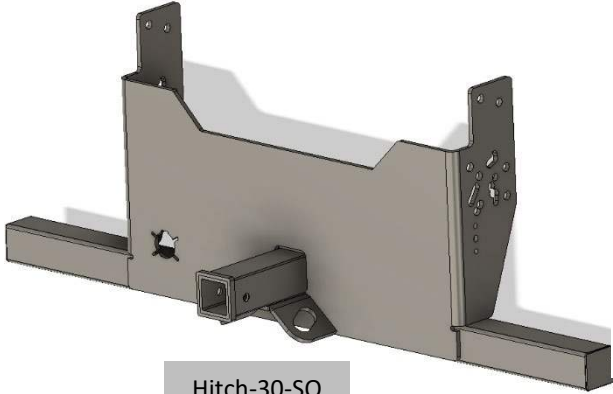

Hitch-30-SO



Hitch-50-SO

(recessed in access door)



Hitch-71-SO Thru Hitch-82-SO

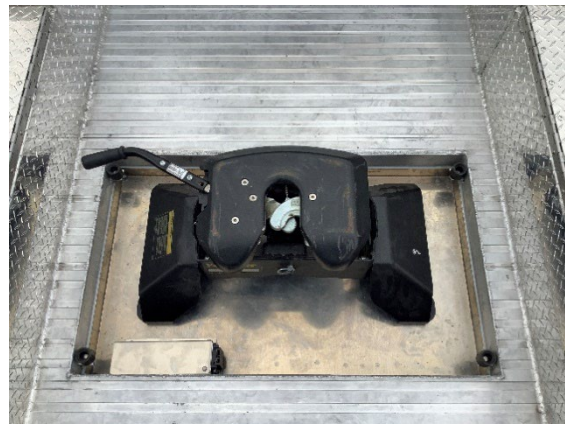

Reusing Factory 5th wheel Puck system

Part#

Decription

- Hitch-30-SO 20K Chassis rear hitch, 2-1/2" reciever
- Hitch-40-SO 25K HD Chassis rear hitch, 3" reciever
- Hitch-50-SO 30k Chassis gooseneck hitch w/ 6.75" rise
- Hitch-58-SO 30k Box delete gooseneck hitch

Truck specific mounting kits, GM, Dodge, Chevy (Please specify)

- Hitch-60-SO 40k Chassis gooseneck hitch w/ 6.75" rise
- Hitch-65-SO 30k Ram gooseneck hitch, 14-newer
- Hitch-68-SO 30k Ford gooseneck hitch, 17-newer
- Hitch-71-SO Chassis Turn-over ball style flush mount hitch, 4" sills
- Hitch-72-SO Chassis Turn-over ball style flush mount hitch, 5" sills
- Hitch-74-SO Universal pickup turn-over ball style flush mount hitch
- Hitch-81-SO Ram 14-newer pickup turn-over ball style flush mount hitch
- Hitch-82-SO Ford 17-newer pickup turn-over ball style flush mount hitch